

Submersible Motors for Screw Centrifugal Pumps

Hidrostal submersible pumps, also suitable for dry installation are efficient, robust and reliable – a tailor-made solution for every application.



Hidrostal Tuma Line

The new Hidrostal motors are available with drive power from 15 - 60 kW and are suitable for vertical and horizontal installation. Thanks to the design with protection class IP68, the motor pumps can be used in permanent flooded operation, but also in dry installation. The cooling is ensured by an internal energy-efficient cooling circuit.

These characteristics make Tuma motors the ideal drive for screw centrifugal pumps to pump unscreened waste water, sludge or other demanding media.

In addition to different speeds and voltages various insulation classes and combinations of construction materials are available. Various protection and monitoring elements ensure maximum safety and reliability.



Pump with highly efficient Tuma submersible motor from Hidrostal

The motor line takes its name from the source of the Rhine, the Lai di Tuma. The transformation of a crystal-clear mountain lake into a raging river inspired us to develop a compact, streamlined pump that offers extensive performance potential. This impressive natural requirement was our inspiration in designing these motors and producing them in a particularly sustainable way.

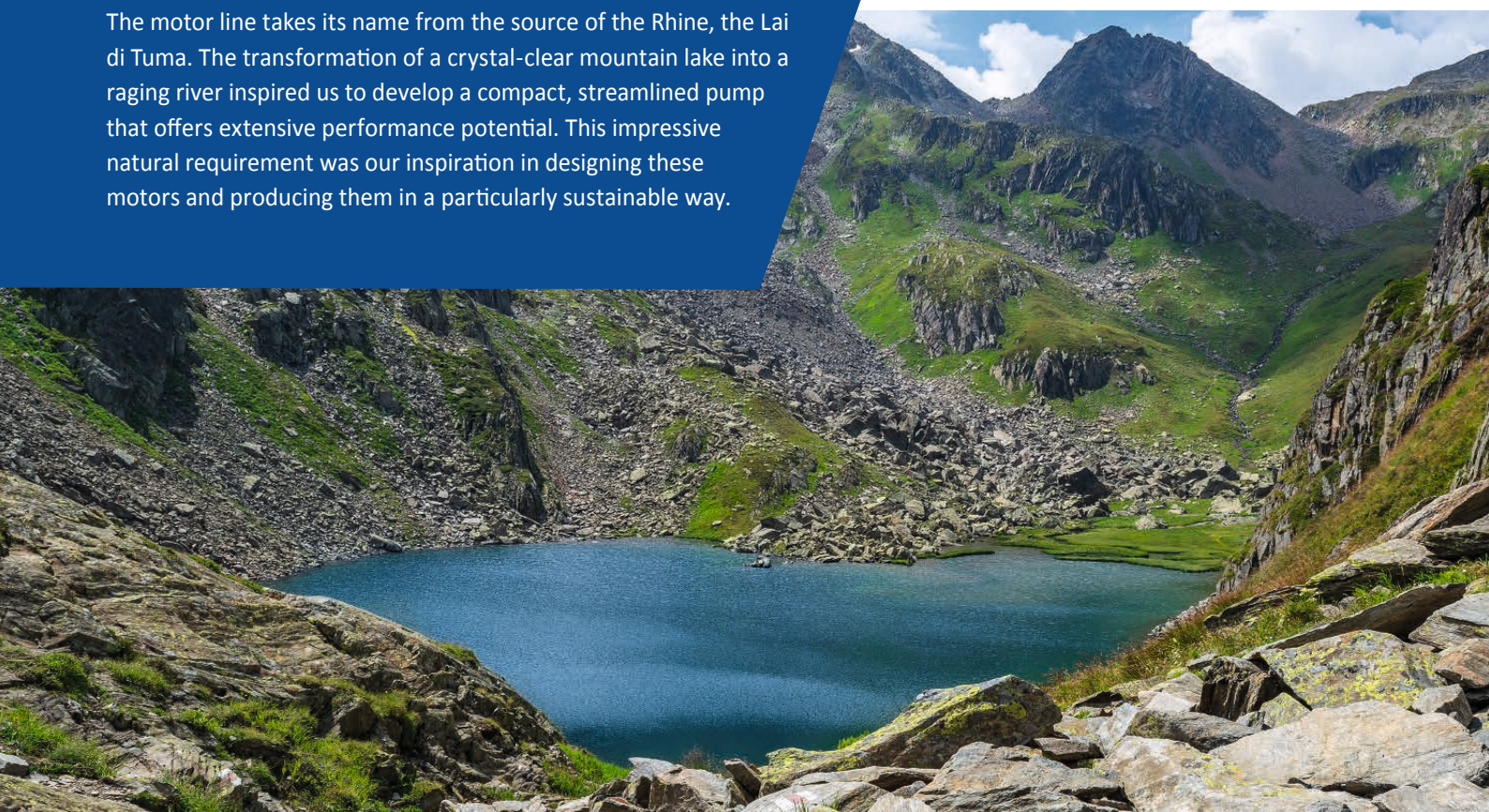

Efficiency and sustainability

Hidrostal Tuma motors ensure premium efficiency to minimize the total cost of ownership for the entire life cycle of the pump.

Although submersible motors are excluded from IEC efficiency classes due to their design, our pumps still achieve the premium efficiency IE3.

Another special feature is that this premium efficiency is achieved in the sense of sustainable production and the complete elimination of rare earths.

The robustness, wear resistance and durability of the individual components also ensure that the pumps have an extremely long product life cycle.

Standard Specifications

- Performance: 15 - 60 kW
- IEC frame sizes: 180 - 225
- Speed: 750 - 3600/min
- protection class: IP68
- Frequencies: up to 66 Hz
- Insulation class: F and H
- Voltages: 220 - 725 V
- Operating mode: Continuous operation (S1)

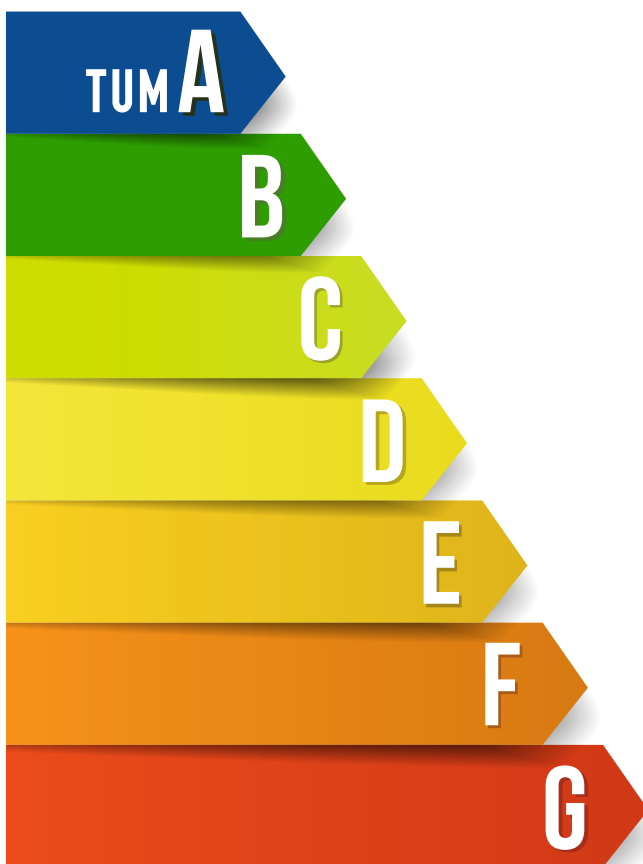

Outstanding Design Features

Functional design

The streamlined surface of the motor prevents solids from adhering to the housing. Especially the very few seams and joints make cleaning much easier and significantly reduce the risk of corrosion. The design, taking into account the Poka Yoke principle, ensures simple and fast service and maintenance work.

Innovative cooling system robust and closed

The innovative, patented cooling system forms a robust, closed circuit. The coolant flows over all external surfaces around the electrically active components and the non-drive-end bearing. The cooling liquid is circulated by a highly efficient cooling impeller, which is located directly on the shaft.

Robust bearing

In the Tuma motors, the shaft overhang has been reduced to a minimum to minimize the forces acting on the bearings. The robust bearings have a minimum service life of 50 000 operating hours (L10h).

Cable connector

Hidrostal motors are equipped with longitudinally sealed cable entries. In the Tuma motors, the entries are pluggable and can be decoupled from the motor for service purposes. The high-quality Duplex cable entries are fitted with hybrid cables, which combine power and control wires in a completely shielded manner.



Versatility is our Strength

Whether for submerged operation, dry installation or for variable level - for every application we offer the best suitable motor with optimum performance. The various material combinations guarantee reliable operation even for difficult applications. Tuma motors are also approved for use in potentially explosive environments. The stainless steel design ensures maximum corrosion resistance, especially in demanding applications.

The extensive monitoring options allow safe operation of the motors. With our many years of experience in the construction of electric motors, we can manufacture any motor pump optimally tailored to your requirements.

- 1 Shaft
- 2 Double mechanical seal in tandem arrangement with various options for mechanical seals on the medium side
- 3 Efficient coolant circulation impeller
- 4 Float switch, leakage monitoring motor dry chamber
- 5 Conductivity probe for monitoring the mechanical seal
- 6 Lower bearing temperature monitoring
- 7 Electrical components with premium efficiency class
- 8 Coolant circulation
- 9 Winding temperature monitoring
- 10 Preloaded deep groove ball bearing
- 11 Separate pluggable cable covers
- 12 Longitudinal cable bushing
- 13 Motor compartment flameproof encapsulation for potentially explosive environments
- 14 Heavy duty rolling bearing
- 15 Barrier fluid and coolant, large barrier medium chamber
- 16 Sealing part with heat exchange surface

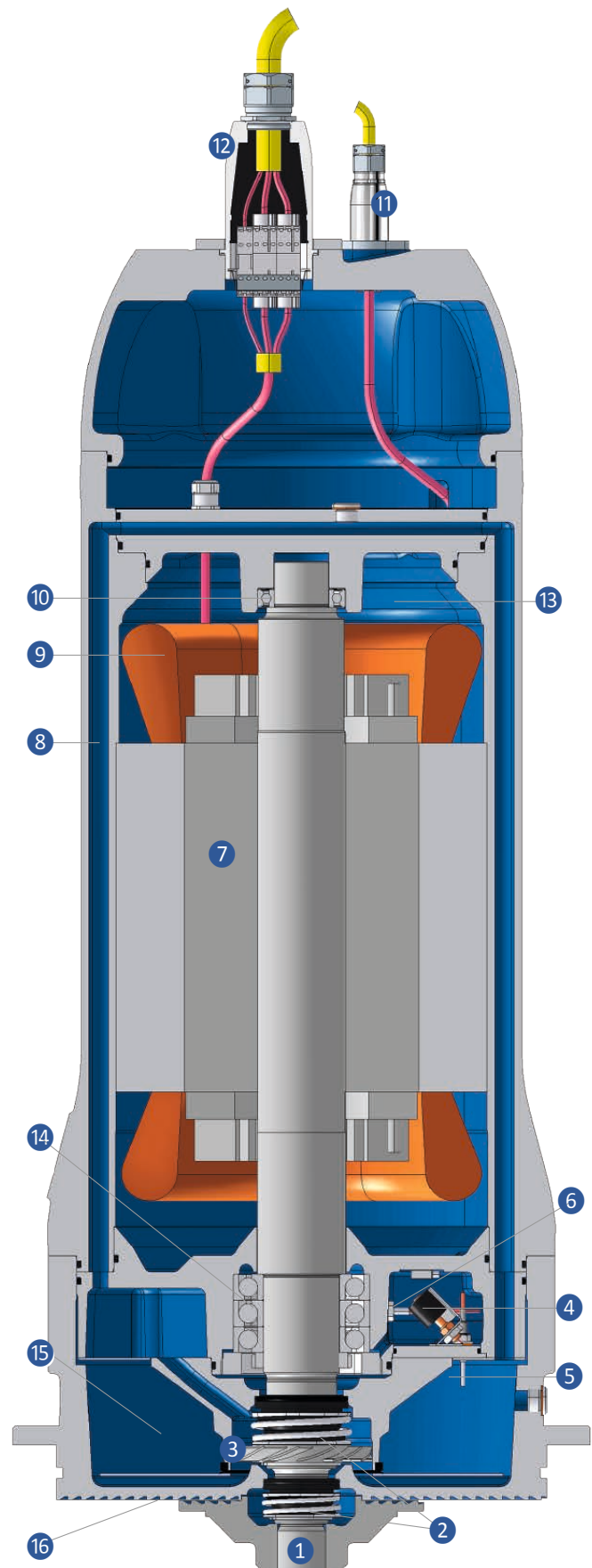

Tailor-Made Options

Explosion Protection

Hidrostal Tuma motors are certified for applications in Ex zones 1 and 2 temperature classes T4, according to the requirements of IECEx, ATEX and FMu. All motors are approved for operation with frequency converters.

Mechanical Seal

Hidrostal offers a premium mechanical seal in addition to a high quality standard mechanical seal. The standard mechanical seal guarantees a very long service life and high reliability for the highest demands on the seal faces. The premium mechanical seal guarantees the same properties, but proves its particular strengths in demanding applications with aggressive media.

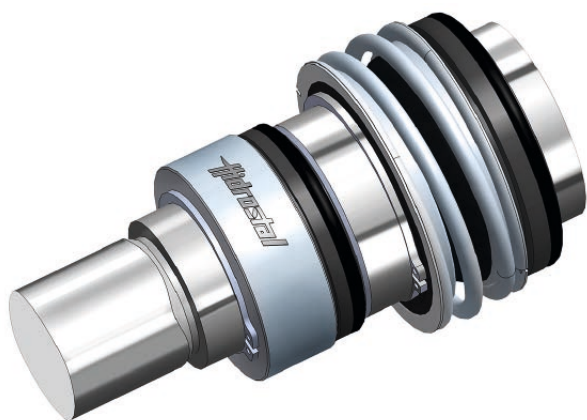

Accessories

A wide range of accessories completes the range. Various accessory options allow the optimum installation of the screw centrifugal pump with Tuma motors in both vertical and horizontal orientation. These include, for example, suspensions certified according to EN 13155, lowering devices but also base plates with pull-out slides.

Material Combinations

The Hidrostal motors are made of proven cast iron. For aggressive media, parts in contact with the medium or the complete motor can be manufactured in Duplex stainless steel. This extends the service life of the components even in challenging applications. All elastomers can be individually adapted according to requirements and application.



Monitoring Elements

For safe operation and effective protection of pump and system against damage, Hidrostal motors are equipped with various protection and monitoring elements. All measured signals are evaluated in the control system and trigger operating alarms to allow scheduling preventive maintenance.

Winding Monitoring

To protect the winding from overheating, bimetallic switches or PTC thermistors are fitted to the winding heads. With the optional PT100 sensors the winding temperature can be measured and evaluated.

Seal Monitoring

For efficient protection of the electrical components and the roller bearings of Tuma submersible motors, both mechanical seals are permanently monitored. This is ensured by a conductivity probe for monitoring the primary (pump-end) seal and a float switch for checking the secondary (drive-end) mechanical seal.

Vibration Sensors

Vibration sensors (XYZ axis) monitor the condition of the vibration-emitting components of the engine.

Bearing Temperature Monitoring

Optionally, operating temperature from both bearings can be monitored with PT100 sensors.

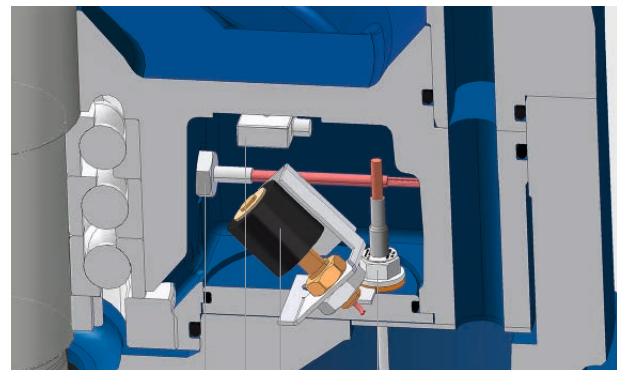

- 1 Bearing temperature monitoring
- 2 Vibration sensor
- 3 Float switch
- 4 Conductivity probe

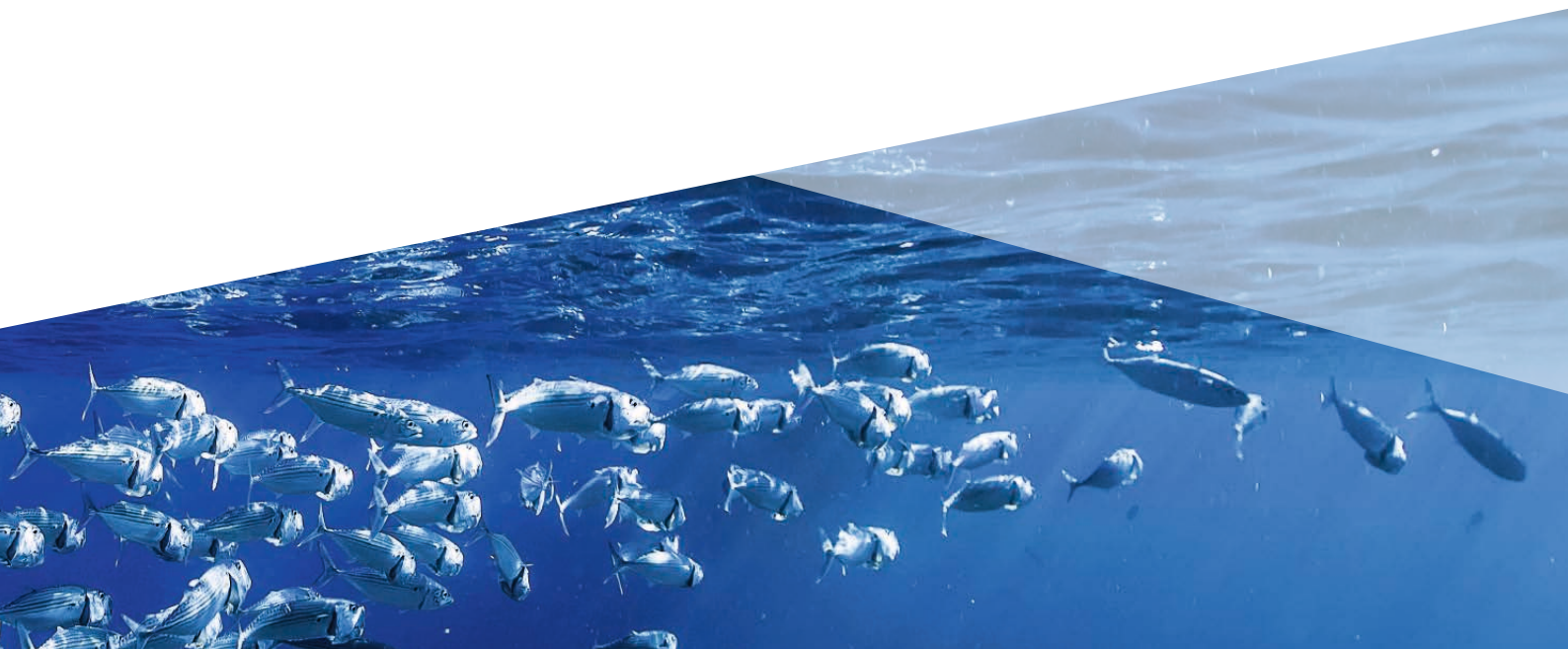

Hidrostal Pumps

Make a quick and accurate pump selection:
www.hidrostal.com/pumpselector.php



Hidrostal pumps are used in numerous branches and industries due to their excellent pumping characteristics. They convey a wide variety of liquids and materials with low pulsation and gentle handling. Our specialists select the suitable material combinations and adapt each pump individually to the conditions on site. This approach ensures that Hidrostal pumps prove their worth even in difficult applications and thus achieve the best results in terms of efficiency, energy efficiency and low life cycle costs.

- non-clogging delivery
- high suction capacity
- gentle conveying due to low shear forces
- high efficiency
- stable characteristic curve
- long service life
- low pulsation
- continuous, speed proportional conveying
- high pressure stability

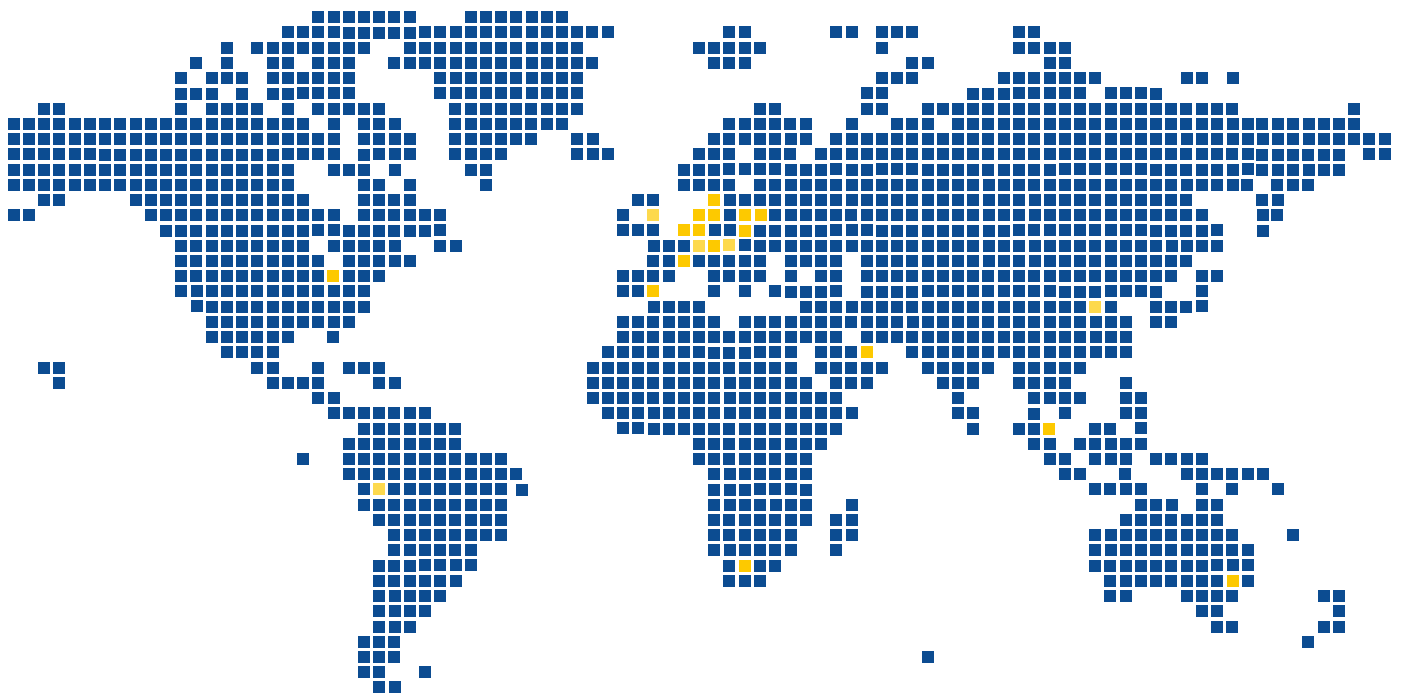
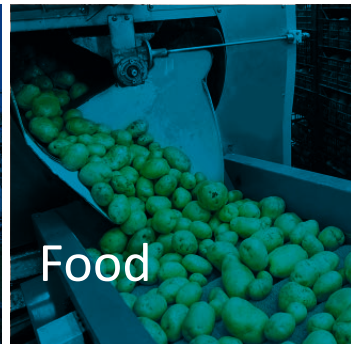

info@hidrostal.com
hidrostal.com

